

CAR



Vehicle History Report

VEHICLE DETAILS

Chassis number ¹: RK5-1032321

Manufacture date: 2010-05-31

Make: HONDA

Model: STEPWGN

Body: DBA-RK5

Grade: SPADA Z

Engine: R20A

Drive: 2WD

Transmission: AT

Title information ²:



Deregistered to Export



Accident / Repair:



No problem



Odometer rollback:



No problem



Manufacturer recall:



No problem



Safety grade ³:



★★★★★



Contamination risk:



No problem



This vehicle does not qualify for Buyback Guarantee

Average Market Price



Unfortunately, this vehicle does not qualify for our Buyback Guarantee program.



¥0

[About Buyback Guarantee](#)

This CAR VX Vehicle History Report is based only on Information supplied to CAR VX, LTD and available as of 2024-08-22 15:44:34. Other information about this vehicle, including problems, may not have been reported to CAR VX, LTD . Use this report as one important tool, along with a vehicle inspection and test drive, to make a better decision about your next used car.

ACCIDENT / REPAIR HISTORY

Problem type	Reported	Date reported	Data source	Details	Airbag
Collision	✔ Not reported				
Malfunction	✔ Not reported				
Theft	✔ Not reported				
Fire damage	✔ Not reported				
Water damage	✔ Not reported				
Hail damage	✔ Not reported				

ODOMETER READINGS HISTORY

Date reported	Data source	Odometer reading (Km)
2021-05-18	MLIT	82600
2023-05-30	MLIT	99700
2024-08-01	MIRIVE Osaka	110111

USE HISTORY

Use in the contaminated regions ⁴	Radioactive contamination test fail ⁵	Commercial use
✔ Not reported	✔ Not reported	✔ Not reported

DETAILED HISTORY

Event date	Location	Odometer reading (Km)	Data source	Details
2010-05-31			HONDA	Manufactured
2010-06			MLIT	First registration
2021-05-18		82600	MLIT	Inspection
2023-05-30	Yokohama	99700	MLIT	Inspection
2024-08-01		110111	MIRIVE Osaka	Auctioned

MANUFACTURER RECALL HISTORY

Date reported	Data source	Affected part	Details
 Not reported			

VEHICLE ASSESSMENT ⁶

Overall Collision Safety Ratings

Driver's seat			Front passenger's seat		
Points	Evaluation	Goal average	Points	Evaluation	Goal average
34.68	★★★★★★	96%	22.89	★★★★★★	95%

* In order to accurately differentiate between the evaluations of different vehicles, a standard is set based on current technology. Up to 6 points out of 12 is given level 1 and the rest of the range is divided up into equal parts, which are respectively assigned to level 2 (more than 6 points but 7.5 or less), level 3 (more than 7.5 points but 9 or less), level 4 (more than 9 points but 10.5 or less) or level 5 (more than 10.5 points).

Braking performance tests ⁷

Dry road



40.6 m

Wet road



43.6 m

VEHICLE SPECIFICATION

1st gear ratio	2.470 ~ 0.450(MANUAL MODE ATTACHING)	2nd gear ratio	-
3rd gear ratio	-	4th gear ratio	-
5th gear ratio	-	6th gear ratio	-
Additional notes	-	Airbag position, capacity	-

Body rear overhang	950	Body type	MV&1BOX
Chassis number embossing position	BONNET INSIDE DASH BOARD UPPER FRONT SURFACE	Classification code	0032
Cylinders	4	Displacement	1990
Electric engine type	-	Electric engine maximum output	-
Electric engine maximum torque	-	Electric engine power	-
Engine maximum power	110/6200(NET)	Engine maximum torque	193/4200(NET)
Engine model	R20A	Frame type	SOLID STRUCTURE
Front shaft weight	920	Front shock absorber type	
Front stabilizer type	TORSION· BAR TYPE	Front tires size	205/60R16 92H DESIGNATION EQUIPMENT ETC.... TIRE CLASSIFICATION EXCEPTING 205/55R17 91V DESIGNATION EQUIPMENT ETC.... TIRE CLASSIFICATION
Front tread	1.470	Fuel consumption	14.0
Fuel tank equipment	60	Grade	SPADA Z
Height	1.815	Length	4.690
Main brakes type	HYDRAULIC TYPE· FRONT DISK· BACK DISK	Make	HONDA
Maximum speed	180	Minimum ground clearance	0.155
Minimum turning radius	5.3... TIRE CLASSIFICATION EXCEPTING 5.6... TIRE CLASSIFICATION	Model	STEPWGN

Model code	DBA-RK5	Mufflers number	1; 2
Rear shaft weight	720	Rear shock absorber type	
Rear stabilizer type	TORSION · BAR TYPE	Rear tires size	205/60R16 92H DESIGNATION EQUIPMENT ETC.... TIRE CLASSIFICATION EXCEPTING 205/55R17 91V DESIGNATION EQUIPMENT ETC.... TIRE CLASSIFICATION
Rear tread	1.460	Reverse ratio	1.735 ~ 1.214
Riding capacity	8	Side brakes type	MACHINE CAR WHEEL SHAPE (DRUM TYPE)
Specification code	16365	Stopping distance	53(100)
Transmission type	AT	Weight	1640
Wheel alignment	2WD	Wheelbase	2.855
Width	1.695		

AUCTION DATA

Date: 2024-08-01, Auction: MIRIVE Osaka, Lot #: 30068

Date:	2024-08-01	Lot #:	30068
Auction name:	MIRIVE Osaka	Region:	
Make:	HONDA	Model:	STEPWGN SPADA
Reg. year:	2010	Mileage (km):	110111
Displacement (cc):	2000	Transmission:	AT
Color:	WINE	Model code:	RK5
Result:	sold	Auction grade:	4
Problem type:	No problem	Problem scale:	None
Contaminated:	No	Airbag:	OK

PHOTOS AND AUCTION SHEETS

MIRIVE 出品票

[1939]

30068

大阪

初年度登録	車名	ドア	グレード	駆動	評価点
H22.6	ステップワゴン スパーダ		スパーダZ	2WD 4WD	
西暦	車種	型式	排気量	保証書	定員
2010	DBA - RK5	2,000	有・無		
走行	S#	車検	色 (Col.No)	燃料	外装
110111	7年6月	ディーラー	色	◎D・電気 (その他)	C C
シフト	エアコン	リサイクル預託金	修正部品	PS	PW
AT	AAC	13,940	AW	エアB	ABS
<注意事項>		登録簿有効期限	<セールスポイント>		
		9月23日	◎ユーザー買取!		
		輸入車			
		ディーラー・並行			
		左H・右H			
<検査員記入欄>					キーロック
Fガラス (キズ・剥離・ヒビ・リペア跡・X要)					ホイール・CPキズ ワレノドアミラーキズワレ 小キズ有 小リ有 補修有
内装 (キズ・スリ・汚れ・シミ・コグ・穴・キレ・破れ・割れ)					
オーディオ (無し・穴) / タイヤ (スタッドレス)					
スマートキー車内					
外装 P.T.C					
R.ワゴン					
ソフトカバー付					
車種	ナビ取付	CDL/SD	B-CAS	リモコン	登録番号
ナンバー	スペアキー	キーレス	スマート		京都 502 さ 981
				車台番号	1032321

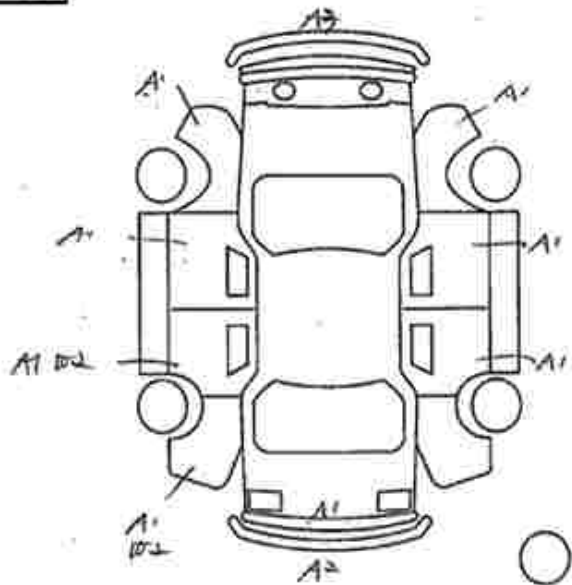

ホイール・CPキズ
ワレノドアミラーキズワレ
小キズ有
小リ有
補修有











¹ Chassis number – a unique identification number of the vehicle in Japan (same as VIN in the USA or Europe)

² Title information:

Registered – qualified for driving in Japan

Deregistered Temporarily – not qualified for driving in Japan, usually a temporary title during the ownership change

Deregistered Completely – not qualified for driving in Japan, the vehicle is determined to be scrapped

Deregistered to Export – not qualified for driving in Japan, the vehicle is determined to be exported

³ Determining the overall collision safety performance evaluation – For the driver's seat, the results of the full-wrap frontal collision test, offset frontal collision test, and side collision test are added together and evaluated to 6 different levels. For the Frontal passenger's seat, the results of the full-wrap frontal collision test and the side collision test (results for the driver's or the front passenger's seat are used) are added together and evaluated to 6 different levels.

Regular vehicle inspection – All vehicles in Japan must undergo regular vehicle inspections (shaken). New cars need to be tested after three years, and then vehicles must be tested every two years thereafter. A vehicle inspection (shaken) is compulsory for all vehicles with an engine size over 250cc. It ensures that all vehicles on the road are properly maintained and safe to drive. The test also checks that vehicles have not been illegally modified; if they are found to have been modified, they are not allowed on the road.

⁴ Use in the contaminated regions – The Fukushima Daiichi nuclear disaster was a catastrophic failure at the Fukushima I Nuclear Power Plant on 11 March 2011, resulting in a meltdown of three of the plant's six nuclear reactors. As a result, some areas in the following prefectures were contaminated: Fukushima, Miyagi, Ibaraki, Tochigi.

⁵ Radioactive contamination test – radioactive contamination inspection that was started in July 2011 as a preventive measure for exporting contaminated vehicles from Japan. The inspection is being conducted since in all sea ports of Japan under the supervision of The Japan Harbor Transportation Association (JHTA).

MLIT – Ministry of Land, Infrastructure, Transport and Tourism.

⁶ Japan New Car Assessment Program – the Ministry of Land, Infrastructure, Transport and Tourism (MLIT) and the National Agency for Automotive Safety & Victims' Aid (NASVA) have taken measures for safety, one of which is to assess commercially available vehicles through a variety of safety performance tests and release the resulting information compiled into the "New Car Assessment Program". The objective of Japan New Car Assessment Program is to increase the use of safe automobiles by providing an environment in which users can easily select such vehicles. This also promotes the development of safer vehicles by automobile manufacturers. Neck injury protection for rear-end collision performance test, rear seat passenger's protection for frontal collision performance test, rear passenger's seat belt usability evaluation test and seat belt reminder for passengers evaluation test are started in FY2009.

⁷ Braking Performance Tests – Braking performance is determined by the shortness of the distance in which a vehicle can stop and the stability of the vehicle at the time of braking. This test is performed under wet and dry road conditions for a vehicle which has both a driver and a front passenger. The distance it takes for the vehicle to stop and the stability of the vehicle at the time of braking is evaluated for when the vehicle is stopped abruptly while traveling at a speed of 100km/h. The stopping distance and vehicle speed have been measured by using GPS since FY2009.

CAR VX, LTD DEPENDS ON ITS SOURCES FOR THE ACCURACY AND RELIABILITY OF ITS INFORMATION. THEREFORE, NO RESPONSIBILITY IS ASSUMED BY CAR VX, LTD OR ITS AGENTS FOR ERRORS OR OMISSIONS IN THIS REPORT. CAR VX, LTD FURTHER EXPRESSLY DISCLAIMS ALL WARRANTIES, EXPRESS OR IMPLIED, INCLUDING ANY IMPLIED WARRANTIES OF MERCHANTABILITY OR FITNESS FOR A PARTICULAR PURPOSE.

© 2014-2024 Car VX Limited. All rights reserved.